

# ROAD MAP FOR THE FUTURE

## MAKING THE CASE FOR FULL-STABILITY



Bendix Commercial Vehicle Systems LLC  
901 Cleveland Street • Elyria, Ohio 44035  
1-800-247-2725 • [www.bendix.com/abs6](http://www.bendix.com/abs6)

# TABLE OF CONTENTS

1	: Important Terms .....	3-4
2	: Executive Summary .....	5-7
3	: Understanding Stability Systems .....	8-12
4	: The Difference Between Roll-Only and Full-Stability Systems.....	13-23
5	: Stability for Straight Trucks/Vocational Vehicles.....	24-26
6	: Why Data Supports Full-Stability Systems .....	27-30
7	: The Safety ROI of Stability Systems.....	31-33
8	: Recognizing the Limitations of Stability Systems.....	34-37
9	: Stability System Maintenance.....	38-40
10	: Stability as the Foundation for Future Technologies.....	41-42
11	: Conclusion .....	43-44
12	: Appendix A: Analysis of the “Large Truck Crash Causation Study” .....	45-46
13	: About the Authors.....	47

# IMPORTANT TERMS

## ***Directional Instability***

The loss of the vehicle’s ability to follow the driver’s steering, acceleration or braking input.

## ***ESPI/ESC: Electronic Stability Program/Control***

Also commonly referred to as “full stability,” this technology is capable of sensing/controlling both directional (yaw) and roll (lateral acceleration) events to maintain vehicle stability.

## ***RSP/RSC: Roll Stability Program/Control***

Also commonly referred to as “roll-only stability.” A system by which only potential vehicle rollover due to high lateral forces (lateral acceleration events) are sensed/controlled in order to help a driver maintain vehicle stability.

## ***TRSP: Trailer Roll Stability Program***

A roll-prevention stability system applied to a commercial vehicle trailer.

## ***Lateral Acceleration***

The acceleration generated from the side force of the tire/road interface transmitted to the chassis of the vehicle. This force can be seen in curve or lane-change maneuvers.

*Before delving into information about the technological differences between commercial vehicle stability systems, as well as the factors fleets should consider when making decisions about stability technology, it’s important to understand a few key terms.*



***Full-stability applications are expanding beyond tractor-trailers and now are available on vocational vehicles, such as cement mixers and motor coaches.***

### Stability Margin

The safety factor provided by a stability system, which is measured by the difference between system-on and system-off performance for the same vehicle, maneuver, and road and weather conditions (keeping the vehicle in the desired path and lane).

#### Calculation of Stability Margin

$$\begin{array}{c}
 \text{Stability Margin \%} \\
 \hline
 \text{With Stability System} \quad \text{Without Stability System} \\
 \text{Speed in MPH* at Rollover} \quad - \quad \text{Speed in MPH* at Rollover} \\
 \hline
 \text{Without Stability System} \\
 \text{Speed in MPH* at Rollover}
 \end{array}$$

**OR**

$$\begin{array}{c}
 \text{Stability Margin in MPH*} \\
 \hline
 \text{With Stability System} \quad \text{Without Stability System} \\
 \text{Speed in MPH* at Rollover} \quad - \quad \text{Speed in MPH* at Rollover}
 \end{array}$$

\*MPH = Miles per hour

### Yaw or Directional Stability

The rotation (spin) around a vertical axis at the CG (center of gravity) of a tractor or truck. When a vehicle is in motion, changes in the vehicle path cause yawing on this vertical axis. For combination vehicles, if the vehicle does not respond correctly to the driver input, this can result in yaw reactions of the vehicle, which are described as over-steer (jackknifing) or under-steer (pushing/plowing of the steer axle) events.

Today's trucking environment is fraught with an increasing number of factors that contribute to accidents – new drivers with limited experience; larger, multi-trailer vehicles; increased load variability; the additional demands on drivers; increased traffic density, numerous in-the-cab distractions; and more. Today's fleets need every opportunity to enhance their overall safety performance, while still meeting the demands of their jobs and the needs of their customers. Stability technologies can give them an advantage.

*As NHTSA ponders mandating stability for commercial vehicles, keep in mind: mandating for today is not enough. Consideration of future needs must be a priority in the decision to mandate stability control for commercial vehicles.*

Stability systems offer a proven way to help reduce the occurrence of loss-of-control events, as well as rollovers. However, not all stability systems for commercial vehicles are the same.

Two basic stability systems are currently available in the North American market: Roll Stability Control (RSC), also known as Roll Stability Program (RSP) – or “roll-only stability”; and Electronic Stability Control (ESC), which is also known as Electronic Stability Program (ESP). Both systems help mitigate the potential for rollovers. But only the ESP/ESC system, also referred to as “full stability,” can help mitigate the loss-of-control events that often lead to rollover.

Regulators have already validated the impact stability systems can have on the safety of our nation's highways. The National Highway Traffic Safety Administration (NHTSA) has mandated ESP/ESC stability systems for passenger cars, light trucks, and SUVs. The regulation takes effect with the 2009 model year, and full compliance is required by the 2012 model year. Currently, NHTSA is considering additional regulation relative to stability technology for Class 6, 7, and 8 air-braked combination vehicles.

In this paper, we'll explore key areas regarding power vehicle (trucks and tractors) stability – from stability basics, to insight about different systems, applications, and implications for the future. Specific areas include:

### ***Understanding Stability Systems***

Stability builds on the ABS system with additional sensors, logic, and use of the brakes to slow and redirect the vehicle.

### ***The Difference Between Roll-only and Full-Stability Systems***

Why full stability is the better rollover mitigation system and how it delivers more performance under a wider range of conditions.

### ***Stability for Straight Trucks and Vocational Vehicles***

A straight truck is different from a tractor trailer and requires a full-stability system, not a roll-only system.

### ***Data Supporting Full-Stability Systems***

A closer examination of the Federal Motor Carrier Safety Administration's (FMCSA) "Large Truck Crash Causation Study" indicates that full-stability systems can do more than roll-only systems to help reduce incidents, save lives, and reduce injuries. Bendix multi-year testing also yields differences in stability margin that favors full- over roll-only stability systems.

### ***The Safety ROI of Stability Systems***

Option cost should not be the basis for choosing stability – effectiveness in reducing accidents is crucial.

### ***Recognizing the Limitations of Stability Systems***

Stability systems do have limitations: they can be overdriven. Skilled drivers who understand these systems are essential.

### ***Stability System Maintenance***

Stability system maintenance is as simple as ABS maintenance, with a few minor exceptions. Optimum performance, as with any braking system, requires proper upkeep and adjustment.

### ***Stability As the Foundation for Future Technologies***

The active safety future – in which automatic brake application helps drivers avoid collisions – is built on full-stability.

### *In a Nutshell ...*

Stability systems offer real value to the fleet, both in terms of safety improvements and financial returns. However, the amount of value delivered can vary and is contingent on the system selected. Different stability systems deliver different levels of performance – not all systems are created equally. In this paper, we attempt to provide insight regarding the various systems to help the reader understand their differences, as well as the reasons full-stability is the optimal choice, not only for today, but also for the future.



***Stability systems can help prevent rollovers, such as the one pictured above. However, stability systems for commercial vehicles vary, and only one system can deliver maximum performance today, while at the same time form the foundation for future active braking safety technologies.***

# UNDERSTANDING STABILITY SYSTEMS

## How Stability Systems Work

Whether they are tractor- or truck-based, stability systems build on the ABS system and utilize sensors to read conditions on a vehicle. When necessary, these systems take action to help slow the vehicle as quickly as possible, enabling the driver to regain control and mitigate a potential rollover. (Full-stability systems go a step further by providing additional performance to help mitigate loss-of-control situations.) Because they can read situations and react, these systems tend to be predictive in nature in that they sense a potential event and typically intervene before a driver can.

All stability systems utilize a means to predict situations and slow the vehicle to help the driver maintain control. The action of slowing a vehicle can involve throttle reduction, use of the engine retarder, and the application of the brakes at various axles of the vehicle combination.

Instability events, such as rollovers or loss-of-control situations, often begin with a steering input – the driver makes a particular maneuver that causes a reaction in the tractor-trailer chain. This maneuver can put into motion the rollover of the trailer or the over-steer or under-steer of the tractor. Stability systems that can read steering input are often able to more quickly take action to reduce the instability in a vehicle, mitigating potential incidents.

## What is Roll Stability?

Roll stability counteracts the inclination of a vehicle (or a vehicle combination) to tip over while changing direction. This tendency typically occurs while turning. Lateral (side) acceleration creates a force at the center of gravity (CG), “pushing” the truck/tractor-trailer horizontally while the friction between the tires and the road opposes that force. (See Figure 1.) If the lateral force is great enough, one side of the vehicle may begin to lift off the ground, creating the potential for the vehicle to roll over. Several factors influence a vehicle’s sensitivity to lateral forces, including the load’s CG height, load offset, road adhesion, suspension stiffness, frame stiffness, and track width of the vehicle.

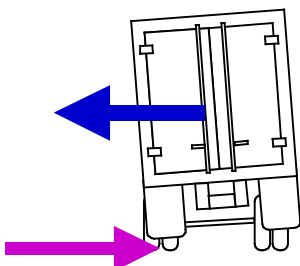

**Figure 1:** This graphic illustrates a vehicle turning to the right and the forces generated at the center of gravity (CG), noted by the blue arrow, pushing the vehicle to the left and the friction of the tire/road interface attempting to hold the vehicle on the road (lateral force), creating the tripping effect that results in a rollover.



### What is Yaw (Directional) Stability?

Yaw stability – also referred to as directional stability – is the ability of the vehicle to follow driver steering input. Factors that influence yaw stability include wheelbase, suspension, steering geometry, weight distribution from front to rear, and vehicle tracking. During operation, if the friction between the road surface and the tractor’s tires is not sufficient to create lateral (side) forces and the conservation of momentum (the vehicle wants to keep going in the initiated direction), one or more of the tires can slide, causing the truck/tractor to spin or push. These events are referred to as either “under-steer” or “over-steer.” (See Figure 2)

*Sometimes, a rollover is about more than the rollover itself. Often, rollovers are preceded by events that create loss-of-control for the driver, such as an avoidance maneuver.*

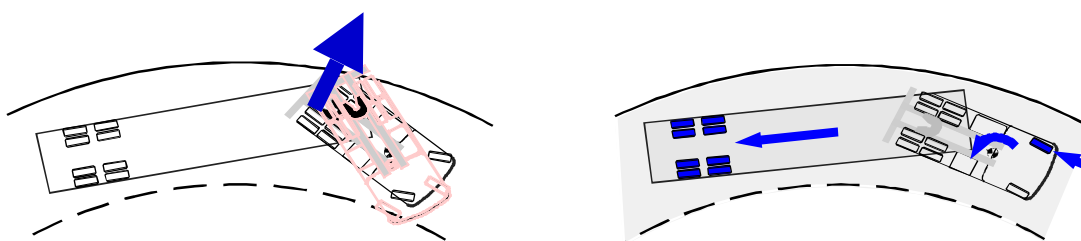

**Figure 2:**  
**Over-steer situation without intervention**

**Over-steer situation with intervention**

Much of the focus on directional (yaw) stability is on over-steer situations, which typically lead to jackknives. But it is important to note that stability systems that offer directional intervention can also impact under-steer situations on roadways. In an under-steer situation, the potential result is not as much jackknifing as it is loss of control (with the potential of the vehicle combination to leave the roadway). During

under-steer, the front wheels are not able to initiate a steering maneuver, resulting in a loss of directional control.

By helping a vehicle maintain directional stability during both over-steer and under-steer situations, the driver’s intended path continues to be followed,



**During demo and testing of stability systems, trailers and straight trucks are outfitted with outriggers to enable full rollover simulation.**

and loss-of-control situations are minimized. This is an important consideration. As this paper will illustrate, many rollovers do not start as lateral acceleration events – or the truck rolling over while traveling in a curve. Instead, they are the outcome of loss-of-control situations that begin when the driver maneuvers to avoid a situation – which, in turn, initiates directional instability – leading to the eventual lateral acceleration event culminating in the rollover.

### ***Commercial Vehicle Stability vs. Automobile Stability***

As noted in the preamble of Federal Motor Vehicle Safety Standard (FMVSS) 126, passenger car instability events are often loss-of-control events (directional instabilities) that result in a rollover. Commercial vehicle instability events are a combination of both loss-of-control and tripping events. Passenger cars do not have the load variation and CG height that commercial vehicles do, so tripping events are less common. Commercial vehicles have a varied CG height and load profile, making tripping events a portion of the causal factors for rollovers. The major rollover causal factor, as with automobiles, is still loss-of-control. Therefore, a full-stability system (ESP/ESC) for commercial vehicles includes both rollover and yaw (directional) control. The vehicle configuration variation (number of axles, wheelbase, combination and vocation, weight, height, etc.) are also significant factors making a full-stability system the best choice for commercial vehicles.

### ***Key Components of a Commercial Vehicle Stability System***

The following diagram (Figure 3) outlines the key components of a stability system. Both roll-only and full-stability systems use a lateral acceleration sensor, but only a full-stability system (ESP/ESC) uses the yaw sensor, which measures the directional stability of the vehicle, plus the steering-angle sensor, which measures the driver’s steering intent for the vehicle.

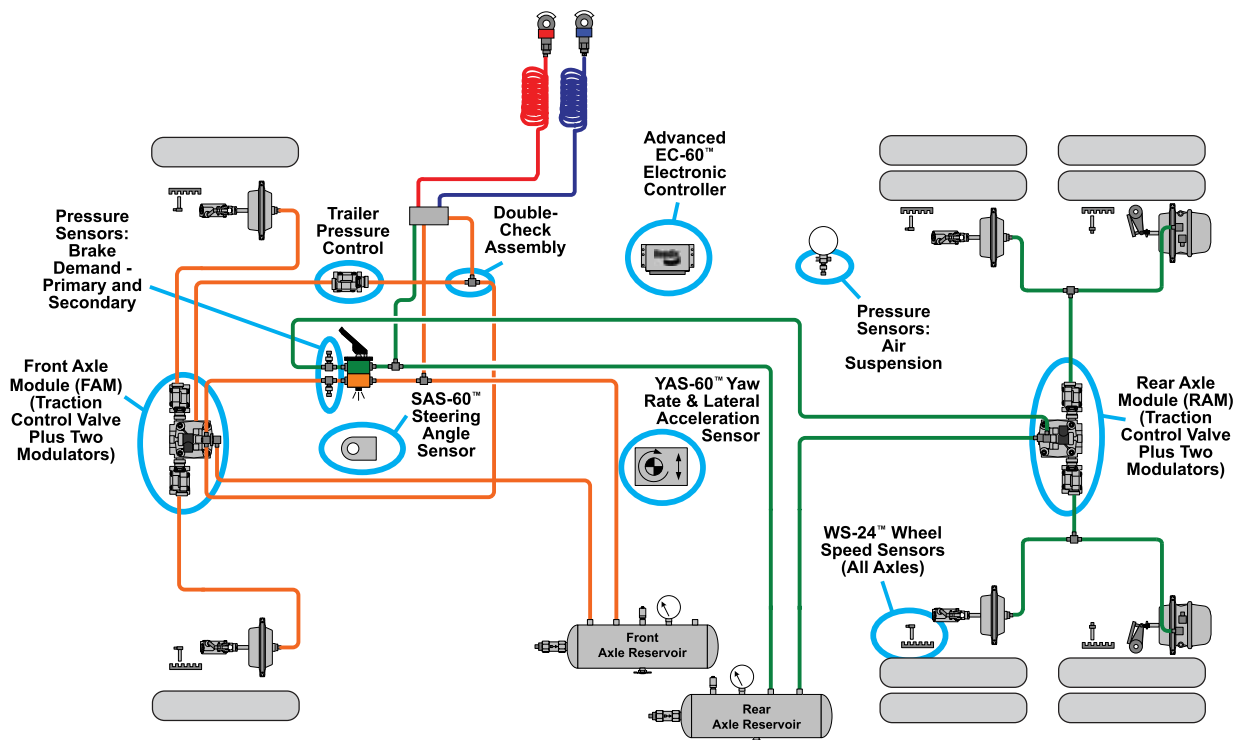

**Figure 3: Key Components of an ESPIESC Full-Stability System**

When it comes to intervention, tractor- and truck-based stability systems typically utilize reduction in throttle (either by directly reducing the throttle, engaging the engine retarder, or a combination of both) and application of the brakes across the various axles of the tractor-trailer combination or truck. Systems differ, however, in which axles are braked, what wheel ends are controlled, and how much brake pressure individual wheel ends receive.

The important distinctions between information delivered via sensors, the intelligence of the electronic control unit (ECU), and intervention capabilities, have an impact on the stability system. These distinctions not only affect a system's ability to help mitigate situations, they also determine the amount of stability delivered to the driver in specific circumstances.

*The pairing of a trailer stability system with a tractor-based system will provide the maximum amount of stability available on a vehicle today. This comes from the added brake utilization of towed units equipped with a trailer stability system.*

### ***Stability Margin as a Performance Measure***

For the sake of stability system comparison, “stability margin” (as previously defined within this document) will be used as the key performance measure. A system with a higher stability margin can help a driver maintain control and mitigate incidents when a vehicle is traveling at higher speeds. This measure is used in the context of this paper as a comparative performance indicator between various stability systems. Bendix does not attempt to define the value of the stability margin across all fleets. Because different fleets operate in different conditions, climates, and geographic areas, only a specific fleet can define its needs and determine the incremental value of additional stability margin.



***Stability margin can be illustrated using the images above. As a representation of the calculation, in the image on the left, the vehicle enters the curve with no stability system and rolls over at 24 MPH. With a full-stability system, the vehicle rolls over at 40 MPH, a stability margin of 16 MPH, or 66 percent.***

Commercial vehicle stability systems are not created equal. There are major differences between roll-only and full-stability systems. These differences are predicated on three key factors:

## ***1. The information collected by the sensors***

The ability to gain insight regarding vehicle dynamics and driver intention is critical to the operation of a stability system. The availability of more information means more data to enable the system to determine what's happening and, as a result, deliver an earlier, proactive response.

## ***2. The intelligence in the ECU used to process information collected from the sensors***

The ECU processes the information derived from a vehicle's various brake and stability-system sensors and then determines and implements an appropriate course of action.

## ***3. The intervention performed by the system to help the vehicle maintain stability***

The intervention delivered via the stability system to help a driver maintain control of his or her vehicle is important. The foundation of all stability systems is the ability to utilize a vehicle's brakes to reduce speed as quickly as possible and help mitigate rollover events. Or, in the case of a loss-of-control or jackknife scenario, slow and/or redirect the vehicle along the driver's intended path.

*The differences between roll-only and full-stability systems are tied to three key factors: the information collected by the sensors for use by the stability system; the intelligence in the electronic control unit (ECU) used to process information collected from the sensors; and the intervention performed by the system to help the vehicle maintain stability.*

### Information: More Sensors Deliver More Insight

A stability system's use of additional sensors delivers further insight and context around the situations a vehicle may encounter, while, at the same time, using more sensors delivers higher performance. The function of the sensors and their availability as part of roll-only vs. full-stability systems is noted in the following chart.

**Chart 1: Sensors Found on Full and Roll-Only Stability Systems**

		Roll-Only Stability Systems (RSP/RSC)	Full-Stability Systems (ESP/ESC)
Wheel-Speed Sensor	Enables the system to monitor vehicle speed and wheel lock-up to optimize braking	✓	✓
Lateral-Acceleration Sensor	Measures the tendency to roll by sensing the side forces acting on the vehicle	✓	✓
Steering-Angle Sensor	First indicator of a potential critical maneuver; captures the driver's intended direction of the vehicle		✓
Brake-Pressure Sensor	Measures driver braking to accurately supplement the driver throughout the maneuver		✓
Load Sensor	Helps verify weight distribution, enabling appropriate application of braking power		✓
Yaw Sensor	Senses vehicle spin to verify that the vehicle is following the driver's intended course		✓

The typical roll-only stability system includes basic ABS sensors, along with a lateral acceleration sensor that reads the side-to-side forces on the vehicle as it maneuvers through a turn. The basic ABS sensors and the lateral acceleration sensor are also included in full-stability (ESC/ESP) systems.

Full-stability systems go beyond just lateral acceleration, delivering additional support in two key areas:

- First, the systems enable understanding of the driver’s steering intent. This is typically accomplished using a steering-angle sensor (SAS) that is designed to measure the driver’s use of the steering wheel to control vehicle direction. With this, the system is able to determine which direction the driver intends the vehicle to go. This sensor is mounted on the steering column, with the steering shaft running through its center.
- Second, full-stability systems also add a directional (yaw) sensor that measures the actual vehicle trajectory. The yaw sensor monitors the rotation of the vehicle around its CG vertical axis and provides an accurate picture of the direction the vehicle is actually traveling. The yaw sensor is typically mounted to the frame, somewhere near mid-chassis on the tractor or truck.

*By using the steer-angle and yaw sensors that are standard on full-stability systems to understand driver intent and vehicle direction, the system can receive the information it needs to intervene sooner, and with selective braking, can help mitigate the loss-of-control situation that could lead to a rollover.*

By utilizing the steer-angle sensor to read driver intent and the yaw sensor to read vehicle direction, a full-stability system is capable of providing support during yaw situations in which the vehicle is not responding correctly to the driver’s input.

In a simplified example, if the driver intends for the vehicle to turn left, he or she steers the vehicle left and the steering-angle sensor reads this information and communicates the driver’s intent to go left to the ECU. The yaw (or directional) rate sensor then monitors where the vehicle is going and also communicates this information to the ECU. If the driver intends for the vehicle to turn left – and the vehicle is, in fact, going left – there is no need for intervention. If, however, the driver turns the vehicle left – and the system senses the vehicle going less or more to the left (than the driver intends), or in another direction – it is able to intervene to help correct the situation. On dry surfaces – because loss-of-control and rollover situations often start with a steering input – evaluation of driver intent, via a steering-angle sensor, can enable faster sensing of a potential instability situation and provide earlier intervention to help prevent the rollover/loss-of-control. On slick surfaces – such as wet, snowy, or ice-covered roadways – evaluation of driver intent and vehicle direction can help determine if the vehicle is in an under-steer or over-steer situation and intervene as appropriate.

### ***Intelligence: Translating Sensor Insight to System Action***

As the sensors deliver information to the ECU, this insight is synthesized using an understanding of what the vehicle is expected to do. This understanding is based on models established in the ECU. These models are made up of algorithms and parameters.

Typically, algorithms are used to compare the data input from the sensors with system expectations about what the vehicle should be doing. While the algorithm itself is important, defined parameters for a particular vehicle configuration are crucial to the performance of the stability system. These parameters define the vehicle model limits of where a system should – or should not – intervene based on the specific stability system for a specific vehicle and load configuration.

A portion of these parameters reflect static vehicle properties such as the wheelbase, number of axles, type of axles (drive, steer, or auxiliary), maximum axle load rating, brake size (force), and suspension characteristics. Other elements of the parameter set are dynamic, such as steer action (which is comprised of steering geometry, steering linkage, Ackerman geometry, and the behavior of these in various steering radiuses and speeds), load of the vehicle, and location of the load. These “dynamic” parameters are continuously monitored by the ECU as the vehicle is driven to modify the intervention points based on specific loading.

### ***Determining Performance Limits: Parameters and Performance Tuning***

It is important to note that system intelligence is not just equipment-based. In many cases, a wide variety of factors are at play for which a vehicle response cannot be simulated. Complete vehicle testing is often required to collect data (this is imperative for those dynamic parameters, mentioned previously, that define the dynamic behavior of the vehicle). Executing a consistent evaluation and input program over the years, Bendix has collected information about vehicle dynamics from testing hundreds of vehicle applications and vocations. From this database, we understand that vehicle response may change, or become unpredictable, when approaching the limits of the vehicle’s capability. As such, Bendix testing activities frequently include pushing vehicles beyond normal road-going limits to understand these behaviors and their potential influence on vehicle stability and system intervention.



The following are used in the development of a vehicle’s performance limits:

- Vehicle configuration parameters, such as gross vehicle weight rating (GVWR) and gross combination weight rating (GCWR);
- Vocational specifics, which provide details about the use for which the vehicle’s chassis was designed; and
- Vehicle characteristics, such as suspension type, wheelbase, axle configuration, etc.

Each type of stability system requires the development of such parameters in order to determine when interventions should occur, and how intense those interventions need to be.

In the “performance tuning” approach to parameter development, the vehicle is tested on a closed course, and a parameter set is derived, which is imbedded in the ECU. For those parameters involving mass and load position and normal changes due to wear of items like tires, a level of self learning occurs through additional driving.

For a full-stability system, such as Bendix® ESP®, the parameter set is developed through performance tuning and extrapolation of the database of vehicles tested, enabling the system to be optimized in terms of performance from the onset.

Performance tuning is considered an optimal approach. Other means of parameter development may under optimize the performance of the system, resulting in either over- or under-intervention, depending on vehicle characteristics and situations.



### ***Intervention: Why More Brakes Make More Sense***

As we discern the differences between roll-only and full-stability systems, we conclude with a discussion about interventions. While both roll-only and full-stability systems provide interventions, full-stability systems provide more robust intervention options, and are capable of taking action that impacts brakes on all axles of a vehicle. Keep in mind, however, that varying situations require distinct interventions, and each unique brand of stability systems may intervene differently.

In a rollover situation in which lateral acceleration is the key influence (e.g., a vehicle takes a curve too fast), the best way to regain stability is to slow the vehicle down as quickly as possible to prevent the roll event. Often, the best way to slow a vehicle is to eliminate throttle and apply the brakes. Although both roll-only and full-stability systems apply brakes, typically, only full-stability systems are capable of applying brakes on all key axles of a vehicle, thus giving a higher deceleration rate to the vehicle in a critical event.

In a directional (yaw) instability event (e.g., in under-steer and over-steer situations), the best way to regain stability is to individually apply corner brakes to slow and redirect the vehicle. To illustrate: In the case of the vehicle experiencing an over-steer to the right, a stability intervention involves braking just the right front wheel, as well as application of the trailer brakes. Only full-stability systems can provide this additional measure of control to the steer axle.

Roll-only and full-stability systems can reduce vehicle speed – either through direct throttle reduction or engaging the engine retarder – but only a full-stability system has the ability to apply the brakes on all vehicle axles – steer, drive, and trailer. A roll-only stability system typically applies only the drive and trailer brakes. The more brakes available for application, the faster the vehicle can be slowed. The steer axle brakes are imperative, especially in the dynamic braking situations described earlier in which as much as 25 percent of the braking can come from the front axle.

*Only a full-stability system has the ability to apply the brakes on all vehicle axles – steer, drive, and trailer. A roll-only stability system typically applies only the drive and trailer brakes. The more brakes you apply, the sooner the situation is sensed, the faster an intervention can occur to help stabilize the vehicle.*

In summary, there are four primary situations that call for the application of steer-axle brakes:

**1. When weight transfers to the front of the vehicle,** such as during a hard brake application. In rollover events, the ability to slow the vehicle as quickly as possible is the critical element. Steer-axle brakes add considerably to the available braking capacity. This is especially true for straight trucks in which braking distribution to the steer-axle may represent a larger percentage of a vehicle’s overall braking capability.

**2. During high-speed maneuvers in potential rollover situations,** in which the tandem tires of the tractor and trailer, or the drive axle on straight trucks, can lift off the ground. If this occurs, the steer-axle brakes provide a much larger percentage of available braking capacity because wheels that are no longer in contact with the road surface are incapable of delivering braking force.

**3. When applying the steer-axle brakes individually for yaw (spin) control.** By applying brakes at any one, or all, of a vehicle’s “four corners,” the stability system may be able to correct the vehicle’s orientation, mitigating the potential for a jackknife, spin out, or slide.

**4. If and when the steer-axle’s contribution to a vehicle’s overall braking capacity/increases.**

This is expected in conjunction with potential stopping distance regulatory requirements that will likely result in larger front brakes.

What does this mean in the real world? It means full-stability systems typically exhibit better performance on dry surfaces than roll-only systems. This translates into a larger stability margin. Thus, a full-stability system can typically help mitigate potential rollover situations at higher speeds than roll-only systems. Let’s consider this last point a little further.

The additional sensors, algorithms, parameters, and braking capability included in a full-stability system enable the system to check and cross-check what is happening with the vehicle and ensure that the stability intervention is timely and appropriate for the specific situation at hand.

Because a full-stability system utilizes additional sensors, it receives the earliest input that a situation may be developing. This early input typically comes from the steer-angle sensor. The stability system is then able to cross-check with other sensors in the system – specifically the lateral acceleration sensor, the yaw sensor and the wheel-speed sensors – to determine what is happening and then deliver the intervention. A roll-only system relies on the lateral-acceleration sensor and the wheel-speed sensors – by the time it receives an initial input and is then able to verify, time passes. Granted, time may be only fractions of a second, but this time lag means intervention comes later, or not at all. If the vehicle speed is approaching the rollover threshold, it’s possible that the stability system can be overwhelmed and not abate the rollover situation. This is why stability margins for full-stability systems are typically higher than for roll-only systems, depending on the scenario. The following figure (Figure 4a) illustrates the value of the steer-angle sensor.

**Figure 4a:**  
**Importance of Steer Angle Sensor in Anticipating Rollover for Combination Vehicles**

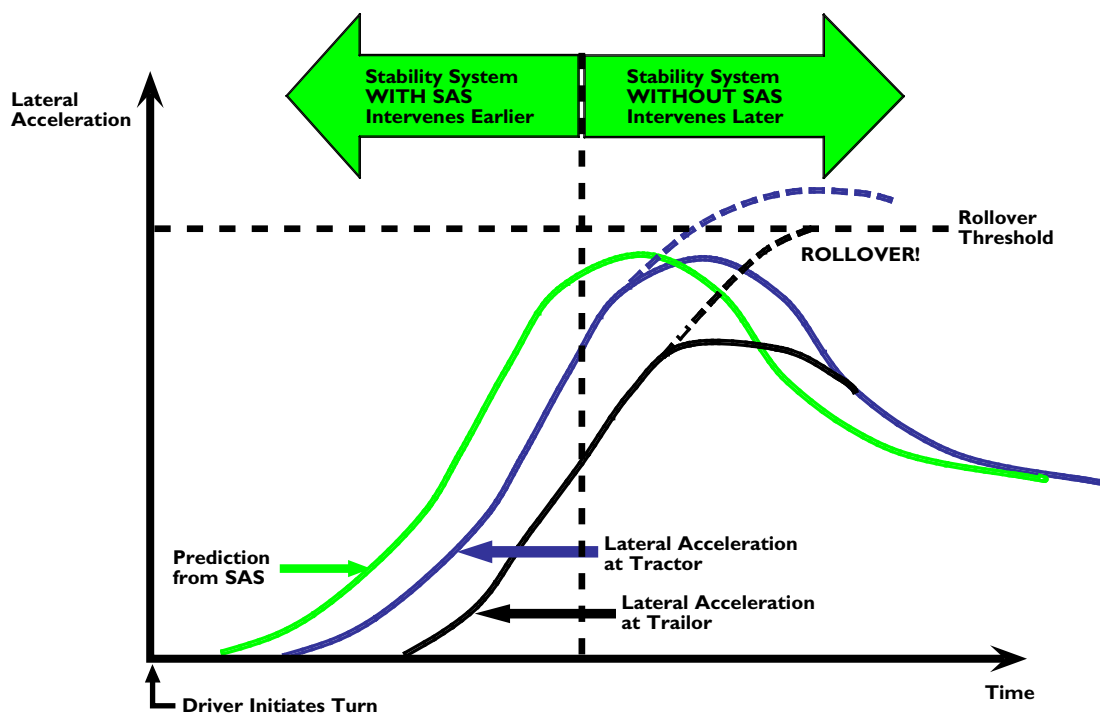

**SAS = Steer Angle Sensor**  
**Rollover Threshold = Critical point at which lateral acceleration results in rollover for steady state conditions for a combination vehicle. (Typically, in a combination vehicle, the trailer rolls and pulls the tractor over, due to the difference in CG heights.)**

With the addition of a steer-angle sensor (SAS), the full-stability system is able to predict a potential rollover earlier than a roll-only system, which typically does not have a SAS. This ability to predict sooner enables an earlier intervention. By intervening earlier, a full-stability system has a better opportunity – across a wider range of speeds – to reduce rollover incidents than a roll-only system.

Earlier intervention, however, is not the only capability that a full-stability system utilizes to respond to an impending rollover. The use of brakes on more axles – steer, drive, and trailer – plus additional braking power, enables the system to provide more brake force to slow the vehicle even faster. Rollover mitigation effectiveness is driven by the ability of the stability system to reduce vehicle speed rapidly. Figure 4b illustrates this point.

**Figure 4b:**  
**Importance of additional braking power in stability system effectiveness**

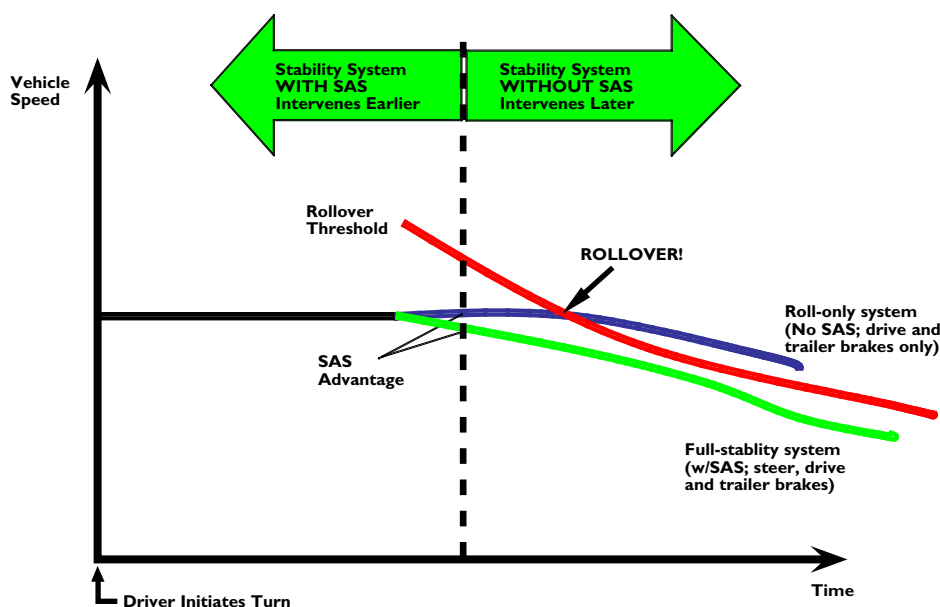

**By being able to predict the rollover sooner, thanks to the SAS, the full-stability system is able to begin braking the vehicle sooner, as illustrated by the “SAS Advantage.” The slope of the curve is steeper for the full-stability system, representing the power of the system and the use of brakes on the steer axle – which typically result in higher deceleration rates than a roll-only system. (Steer-axle brakes can represent up to 25 percent of the vehicle’s braking capability and, perhaps, more in the future as stopping-distance regulation leads to the use of larger brakes.)**

Note: Different situations (e.g., freeway entrance/exit ramps; rapid lane change; avoidance maneuvers, etc.) and different application-specific system tuning will result in differing looks to both Figures 4a and 4b. These graphs are presented in this context as general illustrative references regarding the key differences in stability systems. Also, the focus in this area is on rollover mitigation. As noted earlier, full-stability systems can also help to prevent loss-of-control situations, which often precede a rollover.

In the case of a loss-of-control event preceding the rollover event, this time frame can extend even longer. The primary reasons are two-fold: a roll-only system has no steer-angle sensor and no yaw sensor, therefore it is unaware that the event is occurring until the lateral acceleration comes into play to begin the intervention. Again, the additional sensors in the full-stability system provide additional input to help the system begin earlier intervention.

In closing this discussion on the differences between full- and roll-only stability systems, let's consider the differences in performance from a stability margin perspective. Bendix recently completed another round of roll-only versus full-stability system comparison testing on similar vehicles and trailer loads at the Transportation Research Center (TRC) in East Liberty, Ohio. Running two dry-surface scenarios – a J-curve (akin to a freeway entrance/exit ramp) and an avoidance maneuver (similar to a vehicle pulling out in front of the truck at an intersection) – results indicate a higher stability margin for full-stability systems over roll-only systems. The table below (chart 1) illustrates the concept.

**Chart 1**

Scenario	Roll-only Stability System	Full-Stability System
J-Curve	6 - 7 MPH*	10 - 12 MPH*
Accident Avoidance Maneuver	6 - 7 MPH*	15 - 16 MPH*

\*MPH = Miles Per Hour

Note: Keep in mind that for different situations, conditions, vehicles, and trailer loads, results may vary.

The results illustrate that drivers may have more opportunity to recover from a rollover situation at higher speeds with a full-stability system than with a roll-only system. In other words, full-stability systems can deliver drivers a wider margin of error than roll-only systems. The topic will be addressed further in a later section of this paper.

### ***Traction Control and Stability Systems***

Traction control (TC) is a feature of both roll-only and full-stability systems. TC reduces wheel slip during acceleration, helping to increase lateral stability in the drive wheels and subsequently reducing the tendency for any over-steer, which may result in a power-unit jackknife. When applied to a roll-only stability system, this technology can provide some of the directional stability it otherwise lacks, but its impact is limited to low-speed acceleration events. It is reasonable to conclude, therefore, that TC is constrained in its ability to provide directional stability for a roll-only system and is not a replacement for a full-stability system. By employing the yaw sensor – a standard component of a full-stability system – greater yaw control is gained, further reducing drive wheel slip and providing even more lateral stability at the drive wheels. Yaw control also enables brake application on individual wheels to further correct directional instability.

# STABILITY FOR STRAIGHT TRUCKS/VOCATIONAL VEHICLES

Thus far, this paper has focused on stability factors that are common to tractor-trailer combinations. Straight trucks, however, warrant additional discussion. Because straight trucks possess significant differences in vehicle dynamics when compared to tractors, they have more stringent stability requirements and benefit from more robust stability systems.

*Because straight trucks possess significant differences in vehicle dynamics when compared to tractors/trailers, a full-stability system is the only way to get impactful stability performance.*

## **Straight Trucks and Over-steer**

First, depending on truck configuration and vocation, many straight trucks are susceptible to over-steer. Specific factors that make a straight truck prone to over-steer include: chassis stiffness; load transfer related to roll stiffness in the rear suspension; load concentration and CG, in addition to a tendency for roll steer to occur at higher lateral accelerations. The net effect is a reduction in the effective wheelbase of the vehicle when being driven at higher speeds. This means straight trucks can be even more vulnerable to directional instability, requiring a stability system that includes a yaw sensor that will measure directional instability and enable the system to react. Only full-stability systems include yaw sensors.

Because straight trucks have unique dynamics, the timing involved for sensing an impending loss of stability – and the mass of the vehicle affected by the event – is much shorter. Unlike combination vehicles, the measured lateral acceleration of straight trucks typically has very little lead with respect to the lateral acceleration at the truck's CG. This concept is illustrated in the charts of Figure 5 on the next page.



**Figure 5: Lateral Acceleration Lead Time Differences Between Tractor/Trailers and Trucks**

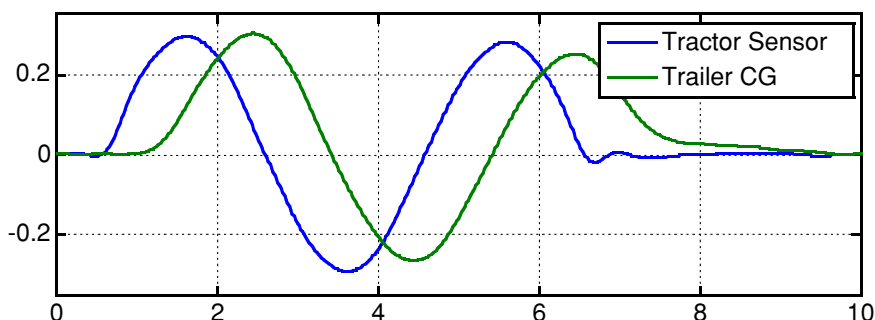

**This chart illustrates a tractor’s length of time in which to sense a stability event, illustrating the lag between the detection by the sensor of a lateral acceleration event (blue line) and the event reaching the CG of the trailer.**

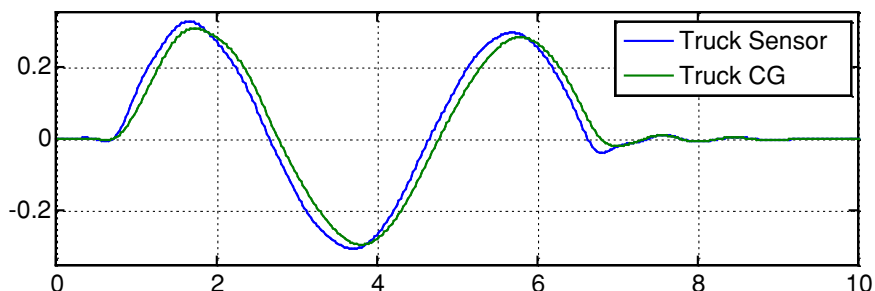

**This chart illustrates this same effect on a straight truck. The lag between sensor and CG is wider for tractors than it is for straight trucks. Therefore, in order to prevent rollover, straight trucks need technology that can read and react to stability events more quickly in order to prevent a rollover.**

For a roll-only system to be effective on a straight truck, it must be tuned to respond more quickly and aggressively than its tractor counterpart. Unfortunately, such “aggressive tuning” of a roll-only system can lead to a secondary issue – yaw instability during roll-only system interventions on high-, medium-, or low-friction surfaces. In general, less braking force is available on straight trucks, so more aggressive corrections can cause other vehicle handling issues that must be monitored, recognized by the system, and mitigated. Thus, the aggressiveness needed to make a roll-only system suitable for a straight truck has a counterproductive effect – it actually creates the potential for additional instabilities when the vehicle intervenes on a dry, wet, snowy, or ice-covered surface, which can be worse than the initial event the system is trying to prevent.

While straight trucks have a gross vehicle weight (GVW) approaching approximately 80-90 percent of tractor-trailer combinations, they typically have less than 60 percent of the braking power. This means a roll-only system that only brakes the rear tandem will provide even less braking power. And although straight trucks often come with additional axles that may have braking capability – such as pusher axles, tag axles, and booster axles – these additional axles are not typically controlled by the stability system.

The lateral acceleration response that is inherent to straight trucks can be addressed by the additional sensors and steer-axle braking available in full-stability systems. Since rollovers tend to begin with a steering input, the steering-angle sensor can provide data to the system to help more rapidly predict those conditions that may require intervention to abate a potential incident. A roll-only system cannot address the directional and control issues that are inherent in straight trucks, and the drive-axle-only braking provided may not provide enough deceleration to make a meaningful impact on vehicle stability.

When considering all of these factors, Bendix has concluded that a roll-only stability system for straight trucks is not a viable solution, since such systems lack adequate performance capabilities to help mitigate rollover situations. A full-stability system is the only recommended choice for straight-truck applications.



***Vocational vehicles, such as cement mixers, need the additional sensors and braking power of a full-stability system to effectively mitigate rollovers. Stability systems that can read and react to steering input are able to more quickly take action to reduce instability in a vehicle, mitigating more potential incidents than roll-only systems.***

## WHY DATA SUPPORTS FULL-STABILITY SYSTEMS

### *Government Studies and Full-Stability*

U.S. Government statistics continue to indicate that rollovers are a major issue in terms of driver safety – about 13,000 rollovers still occur on an annual basis. And rollovers continue to be one of the leading causes of death for truck drivers. In fact, 2004 data from the National Institute of Occupational Safety and Health show that truck drivers face a disproportionately high risk for fatal crash-related injuries, with a fatality rate approximately 11 times the rate of the general worker population.

*According to a Bendix analysis of the data in the FMCSA report, “Large Truck Crash Causation Study,” full-stability systems have the potential to prevent more accidents, save more lives, and reduce more injuries when compared to roll-only systems.*

Aside from the safety implications, a case can be made that stability systems can improve a fleet’s customer satisfaction, as rollovers cause both damage to goods and delivery delays. And, of course, there are also societal costs of each rollover. These costs are tied to productivity decreases and unnecessary fuel consumption brought about by the resulting traffic tie-ups, plus the environmental costs and implications associated with the cleanup of hazardous materials spills.

As noted earlier in the paper, rollovers are often an end result stemming from an earlier event – such as loss-of-control incident. For example, a car unexpectedly crosses the path of a truck at an intersection, or the truck drifts off the road. To avoid or correct the situation, the truck driver may make a quick steering maneuver to avoid the car or get the truck back onto the highway. This sudden change of direction may create an initial yaw event, caused by the trailer pushing on the tractor as the tractor begins the directional change. After this initial event, the lateral acceleration forces begin to impact the trailer, leading to the rollover. These circumstances are often interpreted by their end result – when authorities arrive, the truck is on its side, and the accident is classified as a rollover.

In the Bendix analysis of data contained within the Federal Motor Carrier Safety Administration’s (FMCSA) “Large Truck Crash Causation Study,” 275 cases were found in which a crash occurred because of a heavy vehicle. Of these, 130 (47 percent) were directly related to vehicle stability. In the remaining 145 cases (53 percent), factors outside the realm of stability control – such as incapacitation of the driver or the involvement of a pedestrian – impacted the accident.

As Chart 2 indicates, in those 130 studied events in which vehicle stability was lost, a full-stability system could have mitigated the situation in more instances than a roll-only system. This is because a loss-of-control situation preceded the rollover event. In loss-of-control situations, steering input and direction information is critical to enabling an earlier and more aggressive intervention to help reduce the chances of a rollover.

**Chart 2: Analysis of the FMCSA’s “Large Truck Crash Causation Study”**

Accident/Stability Systems Interaction	Quantity	%	Related Injuries*	Related Fatalities
Cases where stability could have mitigated or lessened the severity of the crash	130		29	12

Stability-Related Cases: ESP Efficacy	Quantity	%	Related Injuries*	Related Fatalities
ESP would have been expected to mitigate the event	88	68%	19	8

Stability-Related Cases: RSP Efficacy	Quantity	%	Related Injuries*	Related Fatalities
RSP would have been expected to mitigate the event	38	29%	9	4

\*Injuries indicated by required transport to medical facility for treatment. Information categorized based on injury or fatality result noted in the specific case studied; no weighting or extrapolation of data used.

When reviewing the analysis outcome, it appears that a full-stability system can provide an opportunity to avoid more incidents that result in rollover than that of a roll-only system. Again, because events that culminate in rollovers often start with other events that may induce yaw instability – such as an avoidance maneuver on a slick surface or a recovery situation (e.g., when the truck drifts off the edge of the road) – a system that can read both the driver’s steering intent and the vehicle yaw (direction) provides a potentially larger margin of safety than a roll-only system. In addition, the earlier brakes are applied – and the more brakes available to be applied – the higher the likelihood that rollover prevention can be successful.

Refer to Appendix A for additional details regarding the analysis procedure used to review the “Large Truck Crash Causation Study.”

### ***Bendix Testing Illustrates the Performance of Full-Stability***

During initial testing at the Transportation Research Center (TRC) in East Liberty, Ohio, Bendix found that – depending on the vehicle, maneuver, and environmental conditions – the additional stability margin\* gained on a dry surface when a vehicle is equipped with a full-stability system versus a roll-only system can range from a few additional miles per hour (MPH) to as many as 16 MPH. This additional stability margin provides the driver with a larger “margin of error” that enables stability through a larger speed differential than that of a roll-only system. As events unfold, this wider stability margin can mean the difference between a vehicle rollover and an intervention that prevents the rollover.



***The photos above illustrate the performance of full-stability (the red vehicle) versus roll-only (the white vehicle) systems on a slick surface avoidance maneuver at identical speeds. The white, roll-only, truck is not able to stay in the lane, while with the full-stability system engaged, the red truck maintains position throughout the maneuver.***

\*Note: Stability margin is dependent on a wide variety of factors and can vary greatly from vehicle to vehicle, based on trailer loads, weather conditions, maneuvers performed, speeds utilized, etc. The same vehicle can also exhibit differing stability margins based on changes in these conditions. A stability margin cannot be determined unless the vehicle is being tested at a test facility with outriggers installed. Stability margin is used as a reference in this case to provide a quantitative and comparable example of stability-system performance.

Bendix also utilized the sealed asphalt (Jennite<sup>®</sup>) surface at TRC to test wet-surface maneuvers. A substantial difference in vehicle control during slick-surface maneuvers was realized. Because a roll-only system does not include steer-angle or yaw sensors, it is not able to interpret under-steer or over-steer situations. Therefore, the roll-only system is unable to intervene to help keep the vehicle under control during slick-surface maneuvers. A full-stability system, which incorporates these additional sensors, is able to intervene by reading the situation and selectively applying the brakes to help redirect the vehicle where the driver wants it to go.

Because a loss-of-control event often precedes a rollover, the implications of the Bendix TRC results are important. By using the steer-angle and yaw sensors (which are standard to full-stability systems) to understand driver intent and vehicle direction, the system can receive the information it needs to intervene both sooner and with selective brakes to help mitigate the loss-of-control situation that could lead to a rollover. Because roll-only systems do not include these additional sensors, they must wait to act until the lateral acceleration has exceeded the threshold required for intervention. This delayed intervention, along with the decreased amount of braking available in these systems, creates a potential risk that the roll-only stability system may not be able to prevent an equivalent number of rollovers as that of a full-stability system.

## THE SAFETY ROI OF STABILITY SYSTEMS

The cost of safety technology can be an impediment to its acceptance. Fleets and owner/operators make a significant investment in the vehicles they put on the road, often more than \$100,000 per unit. And when purchasing numerous trucks, even the smallest cost for a safety device when multiplied over several vehicles and can add significantly to the total cost of new vehicles for the fleet.

Broader economic factors are also an element when it comes to making decisions about investments in safety technologies. Today's fleets are facing a number of increasing costs in their businesses, most notably the cost of fuel and environmental regulations. For example, the 2007 EPA emissions regulations have increased the average price of a new truck by \$7,000 to \$10,000, and while 2010 EPA requirements don't appear to be increasing costs as much, there will be a price to pay. On the other hand, diesel prices near \$5 per gallon, quickly becoming the major operating expense for fleets. As the economy continues to slow and freight traffic is reduced, the ability of fleets to add new vehicles, let alone additional safety technologies, will be greatly impacted.

When it comes to the decision regarding stability systems, option price alone should not be the sole consideration. For example, full-stability systems can help mitigate more types of accidents on a wider variety of surfaces (as noted in the Bendix analysis of the FMCSA "Large Truck Crash Causation Study"); thus, fleets should evaluate not only initial cost, but also the full return on investment (ROI) that can be derived from an investment in such systems. A number of factors should be considered before a fleet can confidently conclude that a roll-only system offers a better ROI than a full-stability system, including:

- types of loads carried and delivery-time requirements;
- experience level of the fleet's drivers;
- routes traveled and weather conditions encountered; and
- monetary and personnel costs of past rollover and loss-of-control accidents.

Improved safety does deliver an ROI for fleets. Safety systems can provide such a return when they decrease the potential number of accidents, as well as the liabilities associated with those accidents. As Paul Knill, general manager of Canadian LTL carrier J&R Hall, noted in a January 2008 article in *Kingsway Express*, “If the system prevents one jackknife or one rollover, it has paid for itself on all of the company’s trucks.”

Let’s look at this statement in more detail. Key is the position that full-stability can help provide instability mitigation in more situations and on more varied road surface conditions than roll-only systems.

The opportunity cost of not being able to mitigate dangerous instability situations can be very high. When the fleet makes a decision to invest in stability as part of its safety package, the choice is really between full-stability and roll-only systems. If we revisit the FMCSA “Large Truck Crash Causation Study,” we can conclude that an investment in full-stability is the right decision. According to the Bendix analysis, full-stability systems are a viable factor in abating up to 68 percent of the accidents labeled as rollover events, while roll-only systems can mitigate less than half that number – only 29 percent. A full-stability system offers 2.3 times the level of mitigation than that of a roll-only system. Taken in context, the incremental cost to the fleet for choosing full stability is less than 1 percent of the price of a new vehicle. The opportunity to abate more potential accident scenarios for minimal additional cost helps justify the slightly higher premium generally paid for a full-stability system purchase.

In financial terms, if a fleet operates with a 5 percent margin, the additional revenue required to recover from the cost of an accident that could have been prevented by a stability system can be very high. To illustrate, a potentially preventable accident that costs the fleet \$100,000 will require an additional \$2 million in revenue to merely cover the expense.

*Consider the facts: A \$100,000 accident for a fleet operating on a 5 percent margin means generating an additional \$2 million in revenue to cover the cost. A \$3 million accident means \$60 million in additional revenue. The more expensive the accident, the more revenue required to cover the cost.*



But oftentimes accidents – especially those that involve fatalities or hazardous material spills – can result in much greater costs. For example – applying the same 5 percent margin noted in the example above – if a fleet experiences a fatal accident that could have been prevented and the resulting cost is \$3 million, the corresponding revenue the fleet must generate to cover those expenses would be \$60 million. Preventing this one accident would justify the additional cost of full-stability for over 3,000 trucks. Small fleet or large, avoiding just one major accident through the use of a full-stability system often justifies the initial cost. And, also as noted earlier, full-stability improves the odds over a roll-only system.

*Full-stability systems go beyond just lateral acceleration to deliver additional support in two key areas: understanding driver intent and determining actual vehicle trajectory. A full-stability system – which uses the steer-axle brakes, along with the drive and trailer brakes – is able to redirect the vehicle to much better match the intent of the driver.*

# RECOGNIZING THE LIMITATIONS OF STABILITY SYSTEMS

Stability systems have limits: they cannot, and do not, replace good drivers and good driving practices. Stability systems also cannot be effective in every type of situation for which their use may be warranted. For example, excessive speed in certain maneuvers can mean that the basic physics of the situation are sufficient to overwhelm the stability system. In these scenarios, while the system may engage, it may not be able to provide enough stopping power quickly enough to prevent a rollover or loss-of-control incident from occurring. While the threshold of incident avoidance may have been surpassed, the system may still have the ability to reduce the severity of the occurrence by reducing the vehicle speed.

*There are limitations to any stability system. So sensible driving practices are, as always, the best way to avoid the possibilities of risk. Drivers need to be aware of stability systems on their vehicles and understand their capabilities.*

Other variables can also impact the ability of a stability system to prevent a rollover. Specifically, in operating situations where the earth may shift unexpectedly – such as on construction sites or off-road – no stability system will prove effective. As well, neither a roll-only or full-stability system will be able to abate incidents where the driver is incapacitated.

## ***The Importance of Driver Training and Education***

In our ongoing conversations with fleets across North America, Bendix has found that fleet executives often debate whether to inform drivers about the inclusion of stability systems on their vehicles. Some fear that if drivers are aware of the existence of the stability system, they may want to drive faster and less safely. Therefore, many fleets may elect to take the position that “what the driver doesn’t know won’t hurt the fleet.”

The reality is, however, that informing drivers about the inclusion of a stability system on their truck is important because both roll-only and full-stability systems can be overwhelmed by aggressive driving habits. No matter the technology, stability systems are not designed to replace good driving practices, but instead to help good drivers avoid potentially dangerous situations, which typically arise suddenly.

## What Drivers Need to Know About Stability Systems

When introducing stability technology to the fleet, a driver education/information program is integral to the success of the technology. Driver education should communicate the following key points:

- **Stability systems are not intended to prevent all situations.** Excessive speeds, varying road conditions, steep shoulders, and a variety of other circumstances can impact the performance of any stability system. Stability systems are designed to help as needed, not to be abused. When the system intervenes, it indicates a potential situation has been addressed. It is not an indication that the driver could have driven at an accelerated speed. Using the system as a means to improve delivery times by faster driving is inappropriate, and it can lead to unintended consequences, such as a loss-of-control or rollover situation.
- **Trip time and fuel economy don't improve when pushing the system.** Stability interventions are designed to slow the vehicle rapidly, requiring quicker acceleration to get back up to speed. It is more prudent and economical for the driver to not have the stability system engage.
- **It is important for drivers who operate different trucks on a regular basis to maintain normal driving practices.** Given the current point in the technology introduction cycle, it is unlikely that all fleets have implemented stability on all their vehicles (though this will likely change as the rate of system purchase continues to grow). Taking this into consideration, it is not unreasonable to believe a driver may operate a stability-equipped truck one day, and a truck not currently equipped with stability the next. The impact of these transitions can be reduced by both ongoing education and awareness, along with a commitment to safe driving practices.



**Not understanding the capabilities and limitations of stability systems can lead to accidents.**

- **Drivers should understand what takes place during a stability event, why stability events occur, and how they can be avoided.**

A stability event occurs because the system interprets that conditions are right for an instability event. As a result, the system intervenes proactively to help mitigate a potentially dangerous situation. When this happens, the driver may notice the stability light flashing on the dash, and he/she may feel a reduction in throttle or the automatic application of the vehicle brakes. This should be an indication to the driver that he/she should reflect on the event to consider what could have triggered the system intervention. Often, drivers report that driving to avoid stability interventions improves their overall driving performance.

No matter the technology, stability systems are not designed to replace good driving practices. Instead, they aim to help good drivers avoid potentially dangerous situations, most of which typically arise suddenly.

- **Fleets should inform drivers about the information that is available from the stability system and how that information will be used to help improve driver training efforts.** Stability systems are equipped to provide fleets with details regarding stability interventions, such as how often the system was activated, what types of interventions were required (roll or yaw), and the “intensity level” of the intervention. This information is available for download and, in some cases, is available real-time via telematics providers such as Qualcomm®. By making this information available, fleets can work with drivers who appear to have excessive interventions, and fine-tune their training to help improve driver performance.
- **Information from stability events should not be used as an indictment of the driver, but instead as the means of helping drivers refine their driving skills.** Likewise, the available data should be used with a level of caution. Interventions alone do not tell the entire story about a particular event. For example, the systems cannot convey whether a driver caused a stability event or if it was caused by the driver’s attempt to avoid a vehicle that cut out in front of him/her. Stability information alone does not completely answer the question. As subsequent safety technologies are integrated, such as Adaptive Cruise Control and Accident Mitigation Systems, additional information will be available that can provide context around specific stability events.

- **Training programs surrounding stability systems should include tools to support stability system educational efforts.** Such tools can be incorporated to help drivers understand the stability system, as well as its functions, features, and limitations. Bendix has developed two useful tools to help explain stability to drivers. The “Driving with ESP” video provides an overview of the system and explains what drivers can expect. And, as part of the information provided with new vehicles, Bendix has developed an “ABS/ATC/ESP Operator’s Manual.” This publication provides overview and operational information about the ESP stability system, as well as the ABS and ATC systems.

Informing drivers about stability and its capabilities and limitations can only help them to more clearly understand the true value and function of these systems. Awareness and knowledge can help reduce the potential for “pushing the system.” This knowledge helps drivers understand that what they do best – driving safely – is still important, even with the addition of stability technology.

# STABILITY SYSTEM MAINTENANCE

It is relatively simple to detect maintenance needs for stability systems, and repairs are easy to make. If there is an issue with the system, a lamp\* on the dash instrument panel will remain lit. In this situation, the vehicle will have partial – or no – stability function, but will remain drivable, with the ABS system still intact. However, the vehicle should be scheduled for service as soon as possible. (\*Note: Specific stability lamps may vary by vehicle manufacturer. Some commercial vehicle OEMs use the ATC [Automatic Traction Control] lamp to represent both stability and ATC. Others use a unique stability lamp. Vehicle owners are advised to check the owner’s manual regarding the correct lamp for their vehicle.)

*Stability system maintenance is built on a foundation of ABS maintenance practices. Most of the procedures used to maintain the top performance of ABS will also apply to keep the stability system in proper working order.*

Because the ABS brake system is the foundation of the Bendix® ABS-6 Advanced with ESP® system, the core components of the full-stability system – the wheel-speed sensors, modulators, traction, relays, and ECUs – are essentially the same. Therefore, current service procedures are similar. The additional components that are part of the full-stability system – yaw and lateral acceleration sensors, steer-angle sensors, and pressure sensors – are based on proven technology with millions of miles in use. Repair to these sensors is limited to direct part replacement and reconfiguration via diagnostic software for the particular stability system. In general, for the specialized sensors that make up a full-stability system, the following basic steps are essential:

- Lateral-Acceleration Sensor and Yaw Sensor
  - The “black box” placed on the frame rail or cross-member near the center of vehicle; usually outside of the cab.
  - At no time should this sensor be moved from its factory-installed position.
  - If moved, the sensor must be returned to its original position and orientation. A recalibration is also required (see next page).
  - No part maintenance is required. This is a replacement-only component.
- Steering-Angle Sensor
  - Placed on the steering column; this sensor is usually inside the cab.
  - Sensor recalibration is required after front-end work is completed (see next page).
  - No part maintenance is required. This is a replacement-only component.

In most cases, other vehicle repairs will not affect the function and performance of the stability system. However, certain types of vehicle repair will require recalibration of select components to ensure optimal system performance:

- **Steering system repairs.** It is important to recalibrate the steering-angle sensor (SAS) when any repairs to the vehicle steering system are made (such as front-end alignments, steering column adjustments, etc.). The procedure for executing this recalibration is typically included in the diagnostic software available for the specific brand of stability system installed on the vehicle. Failure to recalibrate the steering-angle sensor may affect stability system performance.
- **Frame repairs.** Typically, the yaw/lateral-acceleration sensor (the black box attached to the frame rail) should not be removed or repositioned. Any repairs on the frame rail that call for removal or loosening of the yaw/lateral-acceleration sensor will require recalibration of the sensor once it has been properly replaced and secured in the same position and orientation. As stated earlier, failure to recalibrate this sensor may affect stability system performance.

The procedures for these recalibrations are typically part of the diagnostic software available for ABS braking systems, such as Bendix® ACom™ diagnostic software (version 5.3 and higher). Please note: Bendix ACom is designed solely for use with Bendix braking systems.

Any changes made to the tractor or truck, such as the addition of lift axles, frame modifications, etc., should be discussed with the truck OEM. While the addition of vocational bodies typically will not be cause for concern, certain post-purchase changes to the vehicle can impact the performance of the stability system. Should vehicle modifications be required, consultation with the OEM is strongly recommended.

Because it is built on an ABS foundation, the Bendix full-stability system is able to perform only to the extent that the braking system is in good repair. Therefore, standard preventive maintenance procedures conducted at regular intervals for the braking system must be performed. Out-of-adjustment brakes, tread-bare tires, and/or thin linings on brake shoes or brake pads will lead to lower performance of the stability system and can reduce the stability margins during particular interventions. While the system will compensate for normal wear and tear in the braking system, severely out-of-adjustment conditions will impact the system's ability to appropriately act to mitigate dangerous situations. Much as in the case with standard ABS systems, the need to keep brakes on all axles in adjustment and up to specification is critical.



***Because stability technology is built on the ABS brake system, basic ABS maintenance also supports stability maintenance. In order to maintain top operating performance, standard preventive maintenance procedures and braking system inspections should be carried out.***



The new safety technologies on the horizon offer exciting possibilities to help reduce a wide variety of accidents beyond just rollover and loss-of-control. According to the Federal Motor Carrier Safety Administration's (FMCSA) "Large Truck Crash Facts 2006," more than 80 percent of the accidents involving large trucks in 2006 involved some type of collision. The road to true collision mitigation – in which the truck can intelligently take action to help the driver avoid potential collisions – involves both active braking and full-stability systems.

*The road to accident mitigation – in which the truck can intelligently take actions to help the driver avoid potential collisions – involves both active braking and full-stability technology.*

## **Active Braking and Accident Mitigation**

Active braking involves the automatic application of the brakes to help slow or redirect a vehicle, as necessary. As this paper has illustrated, active braking is a key component of full-stability systems. When combined with other sensors – such as a forward-looking radar sensor – automatic application of the brakes can be used to slow or stop a truck to help it avoid a collision with the vehicle it is following.

For example, in advanced Adaptive Cruise Control (ACC) systems, the automatic application of the brakes slows the truck when the vehicle in front of it begins to slow rapidly. This active braking approach serves two key purposes. First, while warning lights and buzzers can become distractions for the driver over time, the automatic application of the vehicle brakes attracts the driver's attention like no other warning can. Second, and more importantly, the fastest way to slow a truck is to engage the brakes. The opportunity to reduce the impact energy of a collision is greatest when using the brakes. By reducing this impact energy, the potential exists to also reduce the deaths, injuries, and damages that are often the result of collisions. The truck may still collide, but because the automatic brake engagement helped to dissipate energy as quickly as possible prior to the collision, the damages or injuries that result from the accident may be significantly reduced.

### ***Why Full-Stability is the Foundation of Accident Mitigation Systems***

The second factor in accident mitigation systems, in addition to active braking, is full-stability. Two points support this statement. First, the addition of stability provides a driver with an opportunity to avoid the collision altogether. How? Depending on the circumstances, the driver might be able to avoid the collision by swerving to another lane or to the shoulder of the road, if clear. In making the maneuver, however, the driver runs the real risk of a potential loss-of-control event or rollover. This scenario is where the stability system comes in, helping the driver maintain control through the maneuver to avoid the collision.

Second, and perhaps more importantly, is the potential for the instability to occur when the brakes are automatically applied as part of the active safety system. Automatic brake applications on wet, snowy, or ice-covered surfaces can lead to directional instability – slide-out or over-steer events that can lead to a jackknife or loss-of-control situation. By including full-stability, with its capability for reading driver steering intent and vehicle direction (yaw), the potential instability instigated by the automatic application of the brakes, can be alleviated.

As we look to an active safety future in which automatic and selective brake application to help vehicles avoid collisions becomes a reality, the need for full-stability systems will continue to increase. Roll-only systems, which don't have all the sensors needed to interpret conditions, pale in comparison as an effective alternative. Therefore, full-stability will need to be a part of those systems that include an active braking component.



***NHTSA's "Large Truck Crash Facts – 2006" reports that 80 percent of highway accidents involving large trucks are collisions.***

# CONCLUSION

Any stability system is a step in the right direction for a fleet. We have all faced situations in our driving lives, whether in a truck or in a passenger vehicle, in which conditions arise quickly that require the need for a quick decision and maneuver to avoid a potential accident. For those who drive commercial vehicles on a professional basis, these “situations” occur more often due simply to the additional time spent behind the wheel and the additional miles driven. The probability of a potential incident increases merely because more opportunities arise during the professional driver’s day.

*Full-stability means more for fleets today and tomorrow. It offers better rollover and loss-of-control prevention than roll-only systems for all applications, including vocational vehicles (such as mixers). Full-stability is the foundation for future technologies that automatically apply the brakes.*

Along the same lines, commercial vehicles are heavier (up to 80,000 lbs.) and tend to be less stable than cars, light trucks and SUVs, leading to longer reaction times and the potential for more adverse reactions when steering inputs are initiated. Straight trucks, which are inherently more unstable than tractor-trailers, become even more unstable when outfitted with bodies – such as rear-discharge mixer bodies – which can raise their center of gravity and increase the risk of instability. Add loads that can increase the CG – such as ready-mix cement or dirt piled high in a dump bed – as well as the increased likelihood of load shifting, and instability is even more significant.



**Unlike roll-only systems that impact only select rollover situations, full-stability systems address both roll and directional stability. While roll-only options function only on dry surfaces, full-stability systems recognize and mitigate conditions that could lead to a rollover or loss-of-control situation in a wider range of driving and road conditions, including dry, wet, snowy, and ice-covered surfaces (and any combination thereof).**

Given the options of tractor-based roll-only systems or full-stability systems, the fleet should choose the full-stability system. The compelling reasons for the selection of full-stability have been presented in this paper, and can be summarized as follows:

- A full-stability system can mitigate more instability situations on more road surface conditions than a roll-only system. The additional sensors in a full-stability system help the system react sooner on dry surfaces and provide for loss-of-control mitigation on wet, snowy, or ice-covered surfaces. Because a roll-only system does not include these additional sensors, it cannot read, nor react to, the situation.
- The incremental cost of a full-stability system is minimal when compared to the overall price of the vehicle. As more OEs move to make full-stability standard, the price tag declines, much the way ABS costs were reduced as it became mandated and more readily available. Maintenance costs of full-stability systems are also relatively low – the only additional time and/or costs are tied to the recalibration of select sensors for front-end work or movement of the sensor.
- Full-stability will be the foundation for future active-safety or driver-assist technologies that utilize the brake to slow or control a vehicle. As fleets move to these technologies, full-stability will become the default stability system. Starting earlier with full-stability technology as part of the fleet buy prepares the fleet for the integration of future safety technologies.

Fleets need to consider not only their requirements for today, but their potential needs for tomorrow in choosing a stability system. The ability to add active safety systems tomorrow requires fleets to have trucks equipped with full-stability today.

Beyond fleets, however, as the government looks to mandate stability technologies for commercial vehicles, it makes sense to mandate the highest-performing system that provides a foundation for the future. Mandating for today is not enough – consideration of future needs must be a priority in the decision to mandate stability control for commercial vehicles. Such was the case when stability was mandated for passenger vehicles, and it should clearly be the consideration for larger, more dangerous, less stable vehicles.

The following points are integral to understanding the Bendix review and analysis of the “Large Truck Crash Causation Study” (LTCCS), which was published in March 2006 following the first-ever national study to attempt to determine the critical events and associated factors that contribute to serious large truck crashes. The study was conducted by two U.S. Department of Transportation (DOT) agencies – the Federal Motor Carrier Safety Administration (FMCSA) and the National Highway Traffic Safety Administration (NHTSA).

- Data analysis was based on the LTCCS database, in which separate data sets were recombined by case number, vehicle number, and axle number for specific criteria regarding the specific accidents, the case worker’s conclusions, as well as the vehicle configuration and performance.
- The full case list was first filtered to identify where the air-braked vehicle was cited as the accident instigator. The justification for this filter is that if the air-braked vehicle hadn’t existed, the accident could not have happened.
- A second filter was based on the type of crash. Basic criteria were used to eliminate pedestrian and simple collisions, such as rear-end collisions with no avoidance attempt. The justification for this filter is that if vehicle stability was not in question – or if under-steer/over-steer elements were not cited – stability systems alone would not have had a significant impact on the event.
- After the application of the aforementioned filters, analysis of the remaining cases was predicated on crash reports, as published in LTCCS data. LTCCS raw data is presented, pending further confidence in weighting factors. Readers should exercise caution before extrapolating information to a national population. See the “Large Truck Crash Causation Study” text first.

- The determination of stability system efficacy is qualitative, based on accident reports. Jackknife, sliding, and over-steer/overcontrol are considered full-stability (ESP) areas. Steady-state lateral accelerations are considered roll-only (RSP) interventions. Overall, transient maneuvers are generally considered ESP areas. Unknowns, or extreme cases were listed as possible, as were cases relating to confirmed load shift.
- Tallies assume that 50 percent of the respective possible incidents were mitigated for all systems. The ESP tally is inclusive of RSP. ESP had higher effectiveness in roll maneuvers, which drove an additional 25 percent of RSP cases into the ESP mitigation sum. Considering all possible cases, it is estimated that accident severity would have been reduced even if total mitigation had not occurred.
- Injuries and fatalities noted in the analysis are to the occupants of the truck only, as reported by the LTCCS.

This white paper was researched and authored by trucking industry veterans with extensive knowledge of and expertise in advanced safety technologies, including:

**Fred Andersky**, director of marketing for controls at Bendix Commercial Vehicle Systems LLC, a marketing professional who has spent countless hours in discussions about active safety technologies with commercial vehicle fleets and owner-operators throughout North America. Possessing a CDL in Ohio, Andersky spearheads a variety of demonstration events across the country, enabling commercial vehicle industry participants to witness, firsthand, the benefits of advanced safety technologies. During his tenure with Bendix, Andersky has become a strong advocate for active safety technologies that are designed to advance commercial vehicle safety. He has presented to, and worked alongside, a variety of industry, regulatory, and legislative groups regarding the importance of active safety technologies for commercial vehicles.



*Andersky*

**Rick Conklin**, product manager for Bendix® ESP® and future architecture at Bendix, a registered professional engineer with 14 years of experience as part of the Bendix team. Conklin is a forward-thinking professional who has been instrumental in creating a vision for next-generation brake systems and the benefits integrating other systems with brakes can bring. During his career in the trucking industry, Conklin has held lead roles in the development of air dryers, valves, electronics, and air disc brakes. He holds four U.S. patents and is recognized in the industry, having served as a speaker for a variety of educational events. Conklin has also been active with the National Highway Traffic Safety Administration and the Truck Manufacturers Association in their legislative work on behalf of vehicle stability and accident mitigation technologies that can benefit public safety.



*Conklin*

Additional support for this publication was provided by the Bendix electronics engineering team.



Bendix Commercial Vehicle Systems LLC  
901 Cleveland Street • Elyria, Ohio 44035  
1-800-247-2725 • [www.bendix.com/abs6](http://www.bendix.com/abs6)